

# Virtual, Immersive and Augmented Reality – Feasibility Study On The Applications Of The HVRC VRdose Planner

**Qasim Kapasi**

MEng Mechanical Engineer – AMIMechE  
Engineering Design – Fuel Cycle Solutions

IFE international Workshop

7-9 February 2017

Sarpsborg, Norway



- National Nuclear Laboratory

- Project Scope

- HVRC VRdose Planner

- Design Simulation

- Potential Applications

- Summary



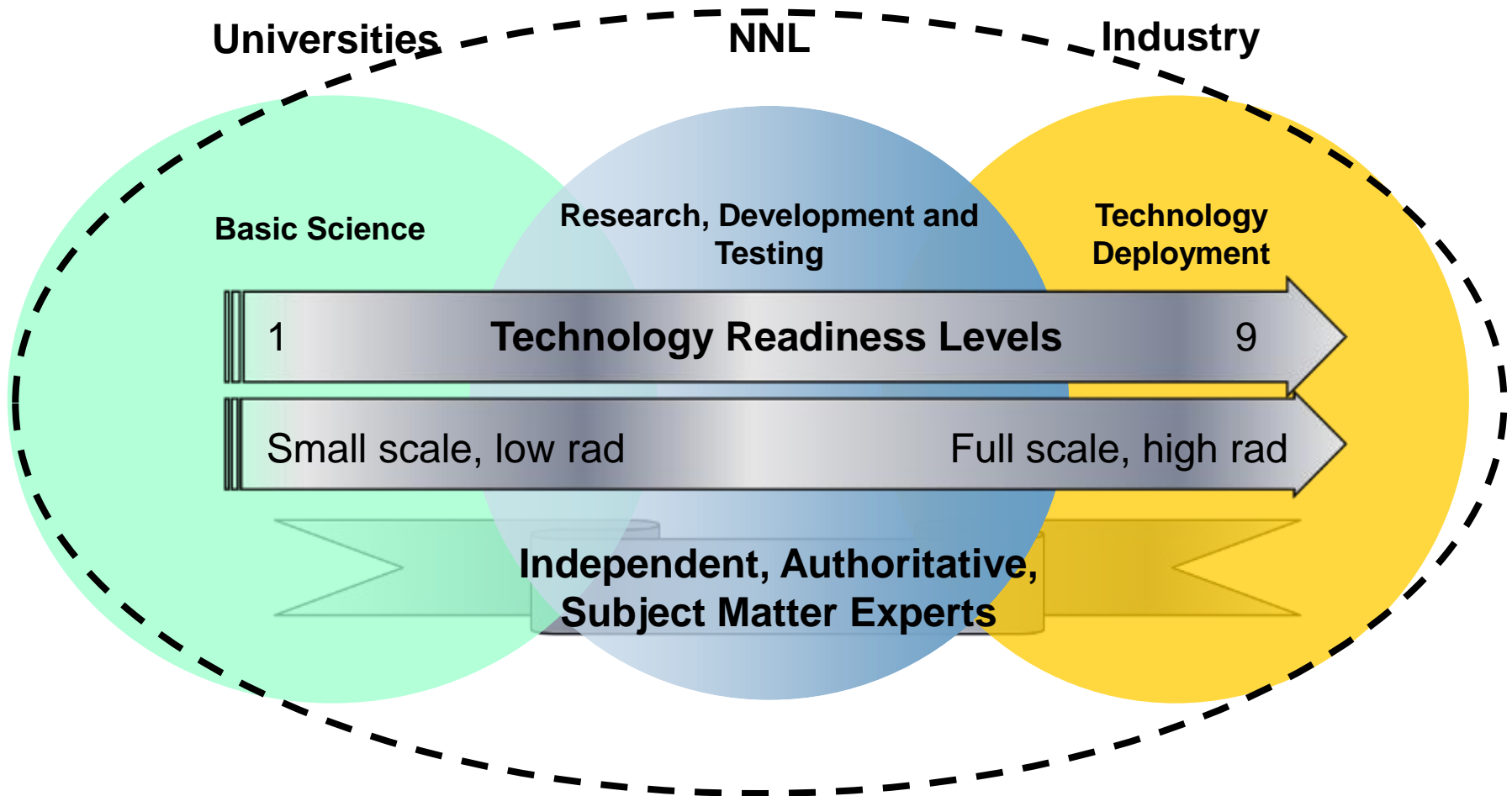

- Nuclear industry is generally resistant when using new technology for the purposes of design and development
- IR&D project focused on developing NNL's immersive and augmented modelling capabilities
- Vision – To develop a state of the art capability applicable to nuclear design and decommissioning
- Two strands:
  - Virtual Glovebox
  - HVRC VRdose Planner

# Virtual Glovebox

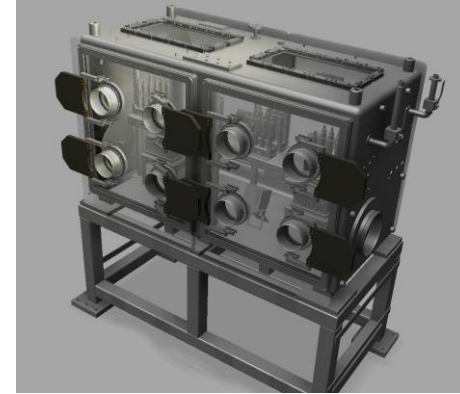
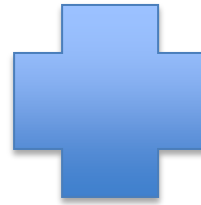

- Developed by Institute for Energy Technology at the Halden Virtual Reality Centre (HVRC)
- Simulate and mitigate radiological risks in a 3D virtual environment
- Provide an interactive virtual representation of an active area with all associated radiological risks
- Feasibility study testing software capabilities in an NNL industrial application



- To develop a radiological assessment of installing a Pneumatic Transfer System (PTS)
- Three studies:
  - PTS Design
    - Optimum shielding material with respect to dose
    - Optimum pipe thickness with respect to dose
  - Operator Activities
  - Blockage



# Simulation

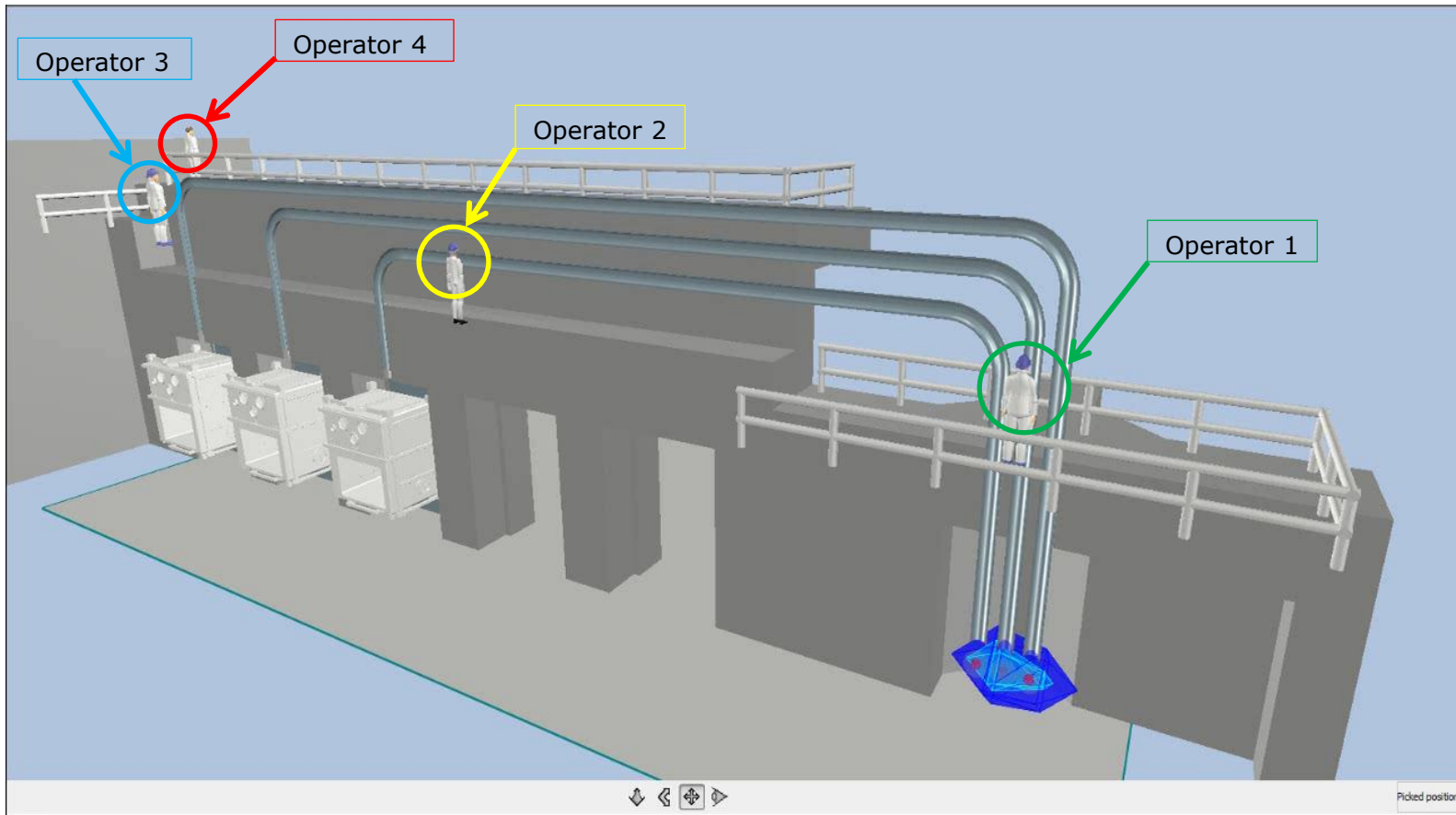

- Operator 1
- Operator 2
- Operator 3
- Operator 4

# Simulation Design

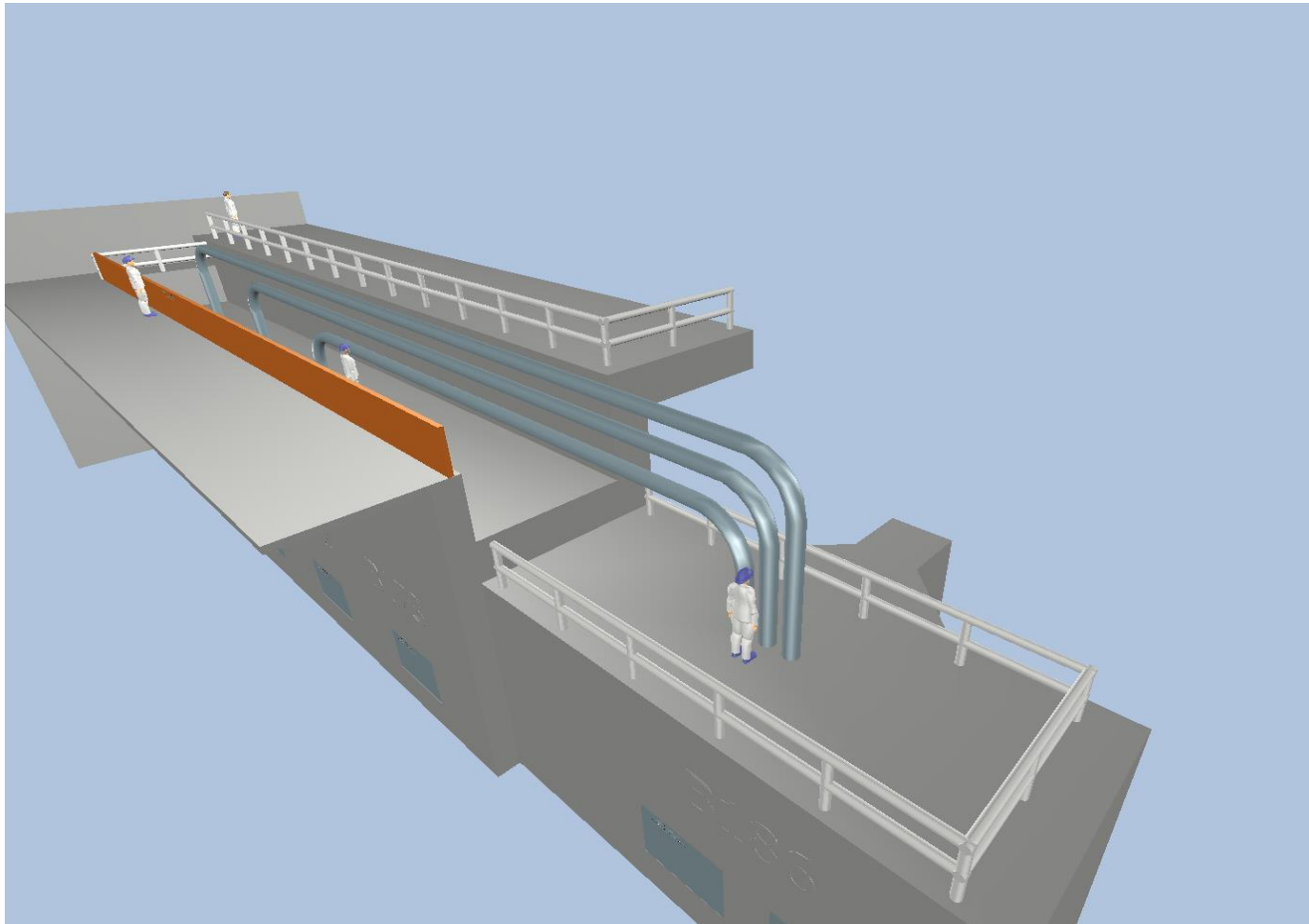

# Optimum Pipe Specification

## Three common piping materials:

- PVC – simulated by no shielding properties
- Stainless Steel – simulated by Iron
- Lead – simulated by Lead

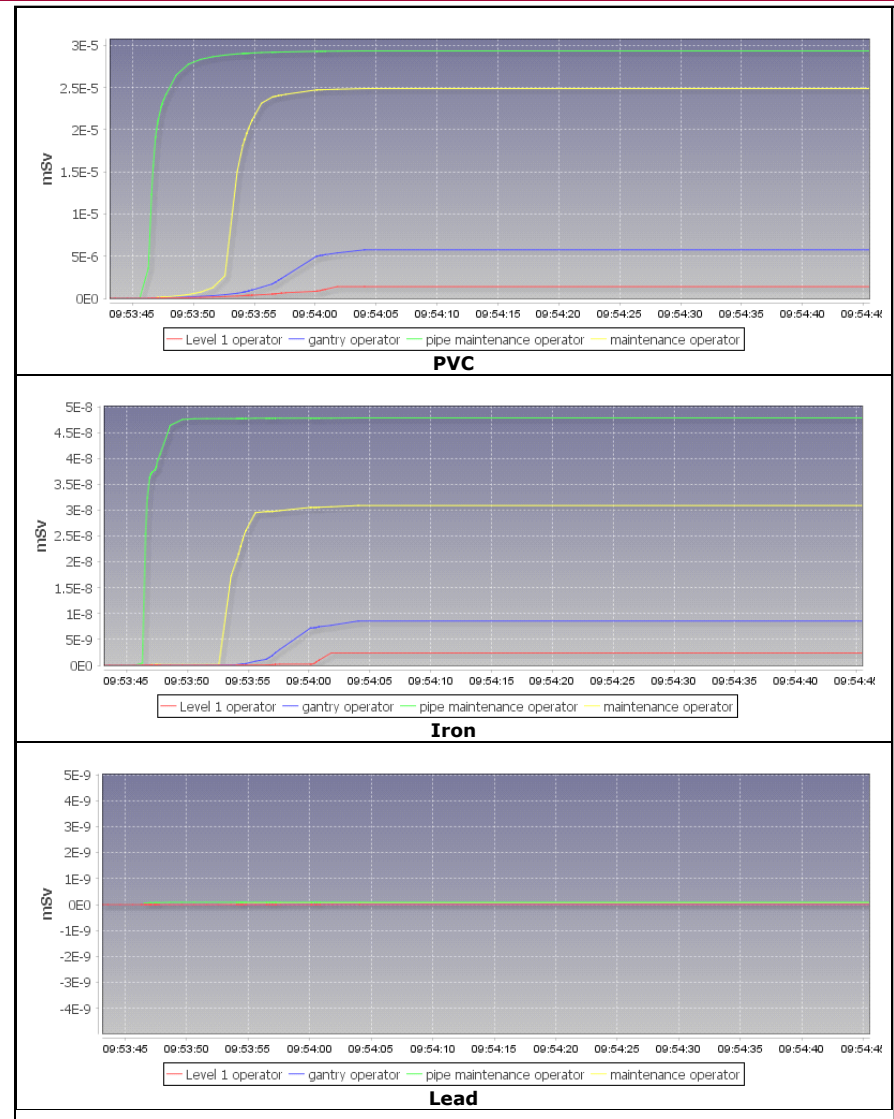

# Optimum Pipe Specification - PVC

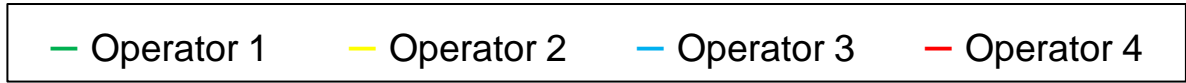
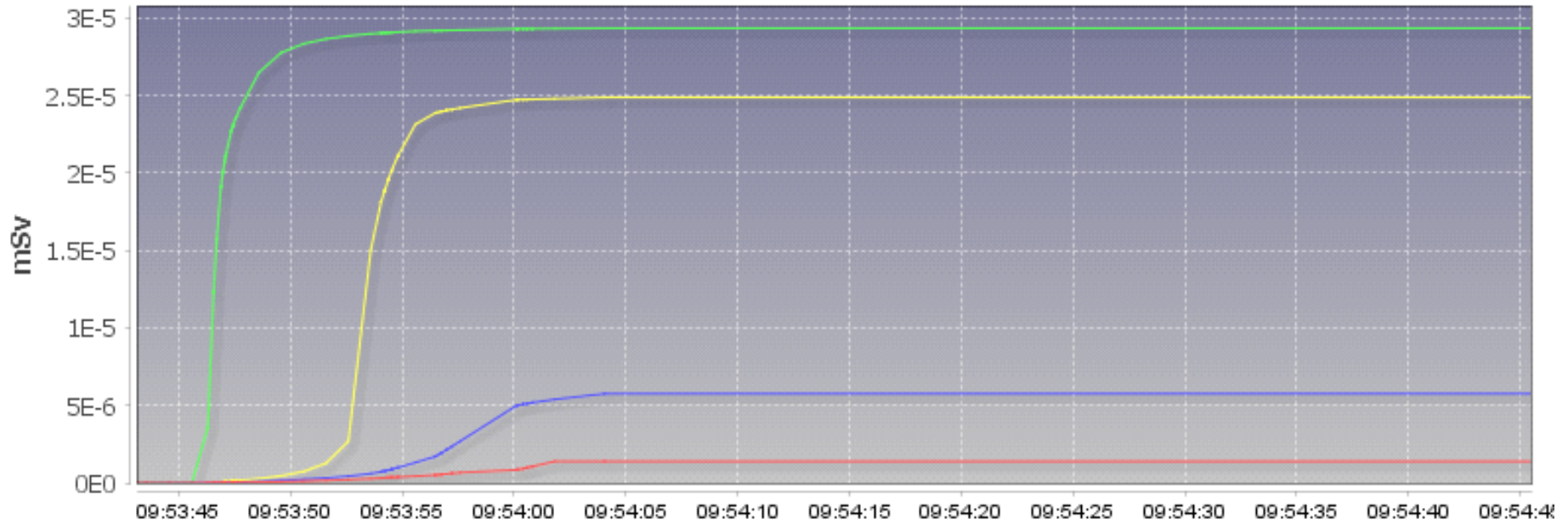

# Simulation

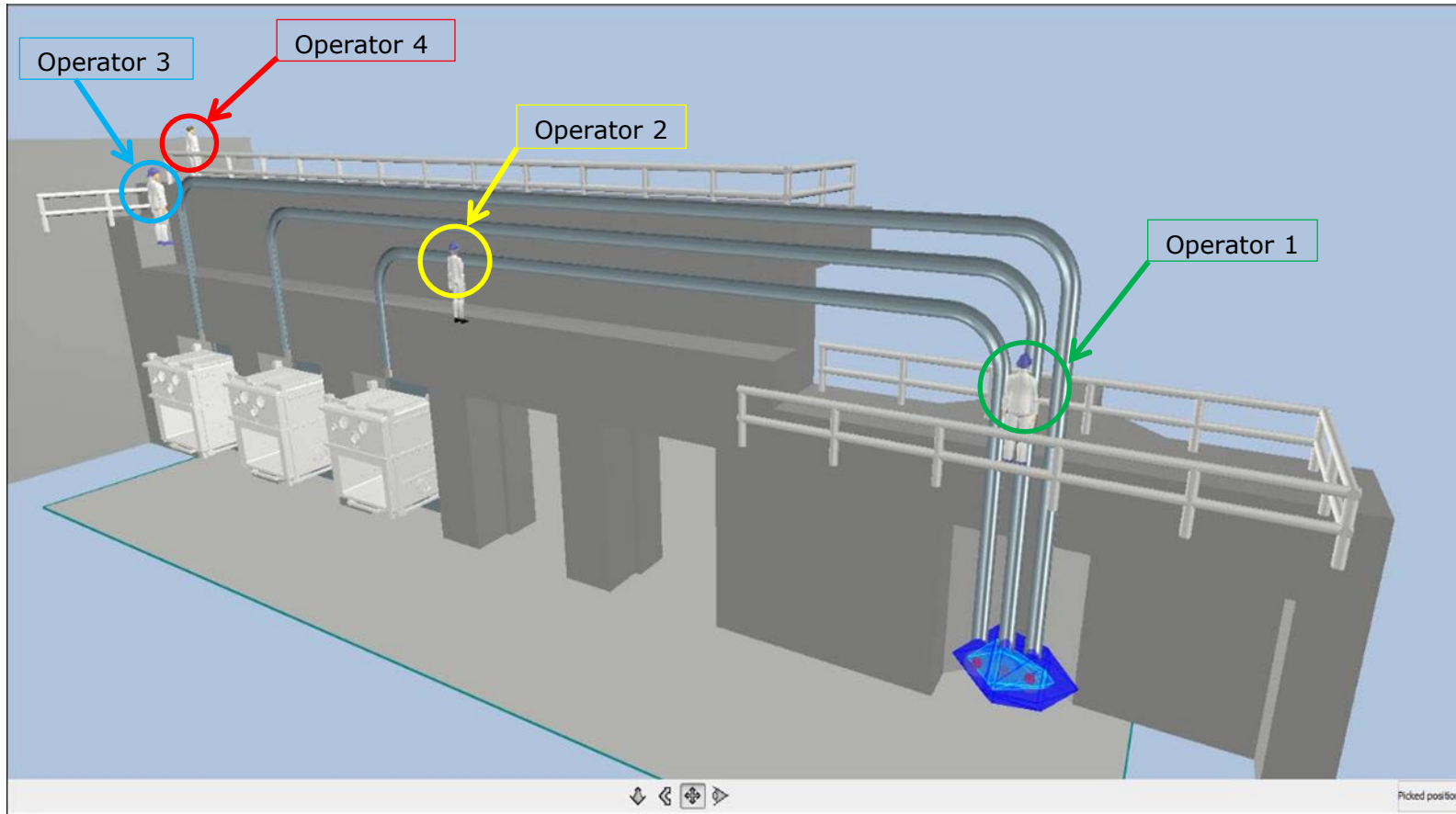

- Operator 1
- Operator 2
- Operator 3
- Operator 4

# Optimum Pipe Specification - Iron

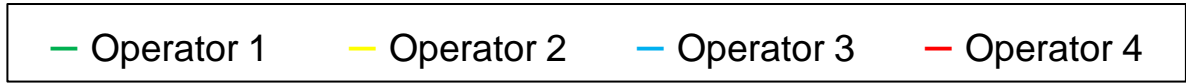
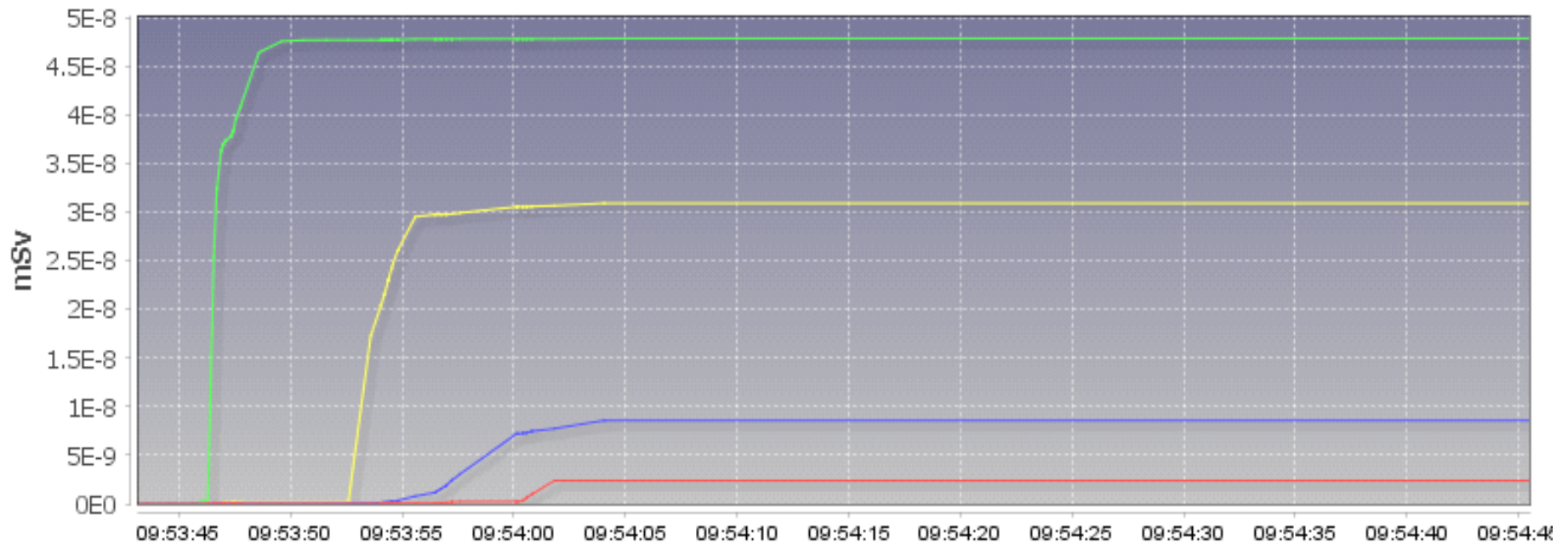

# Optimum Pipe Specification - Lead

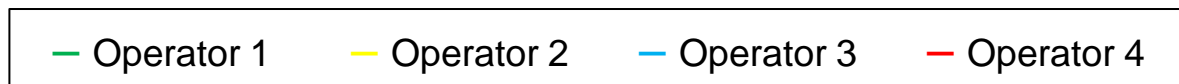
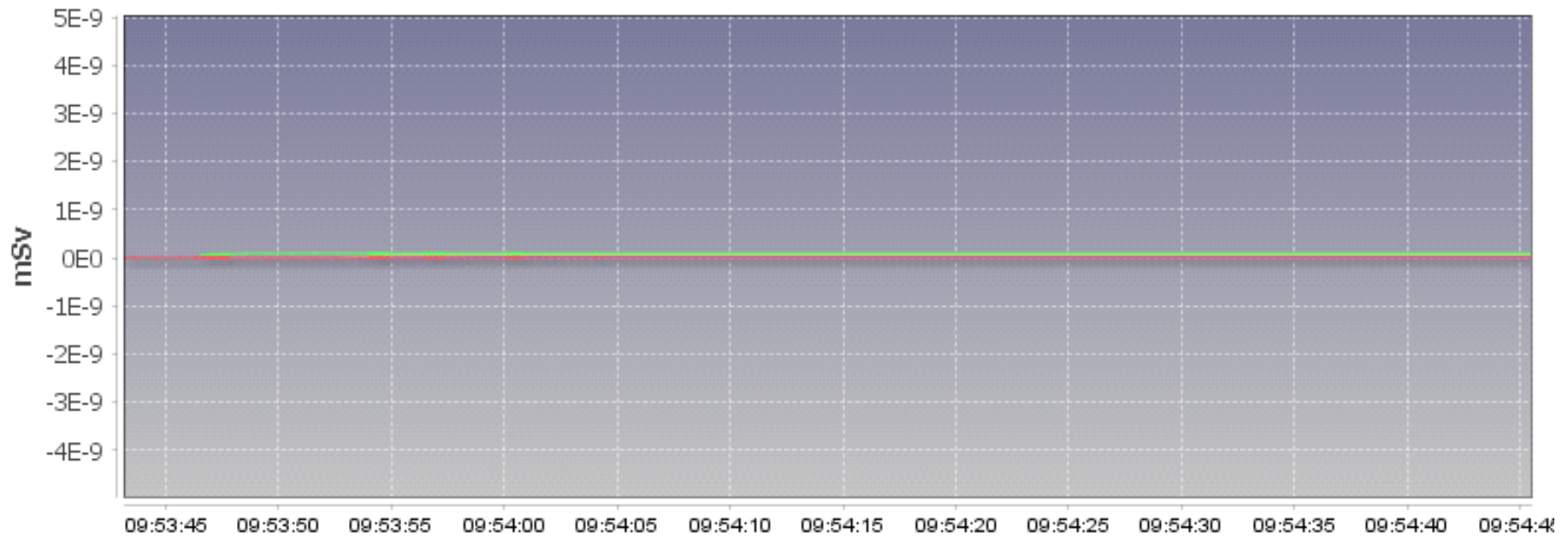

# Optimum Pipe Specification

- Three thicknesses:
  - 25 mm
  - 15 mm
  - 10 mm

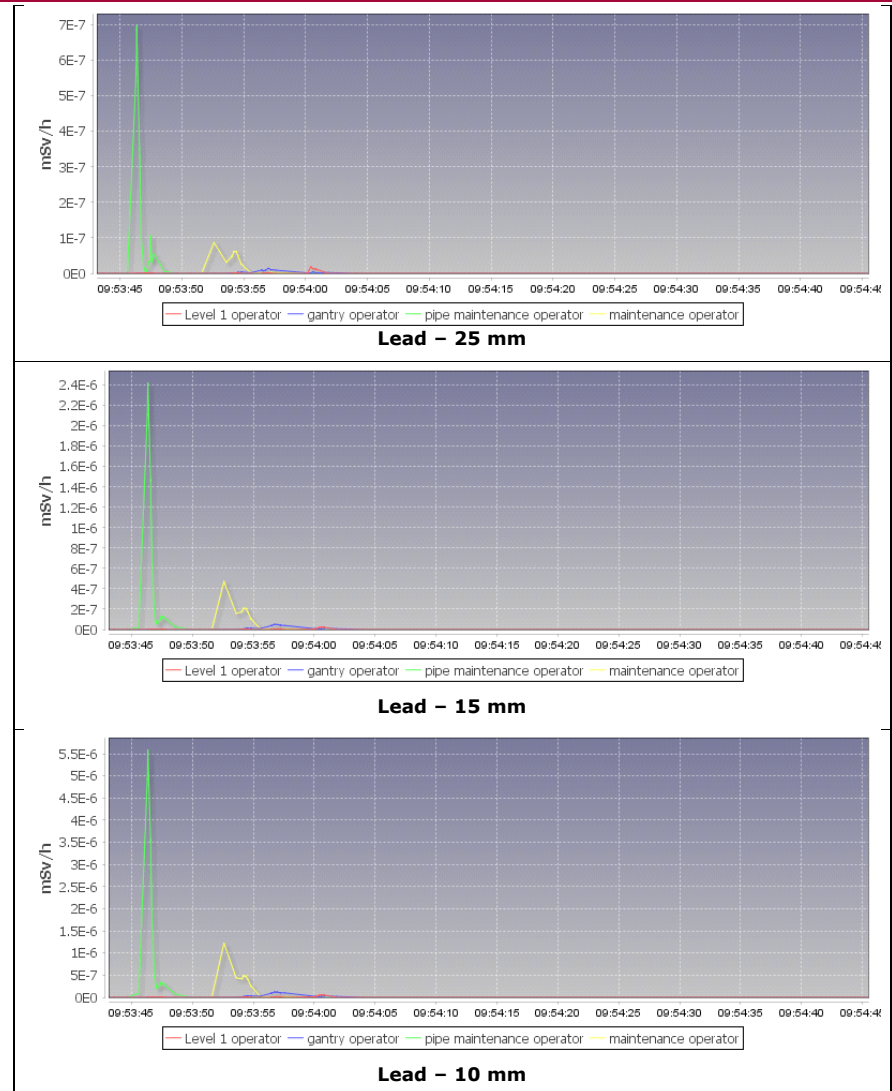



# Optimum Pipe Specification

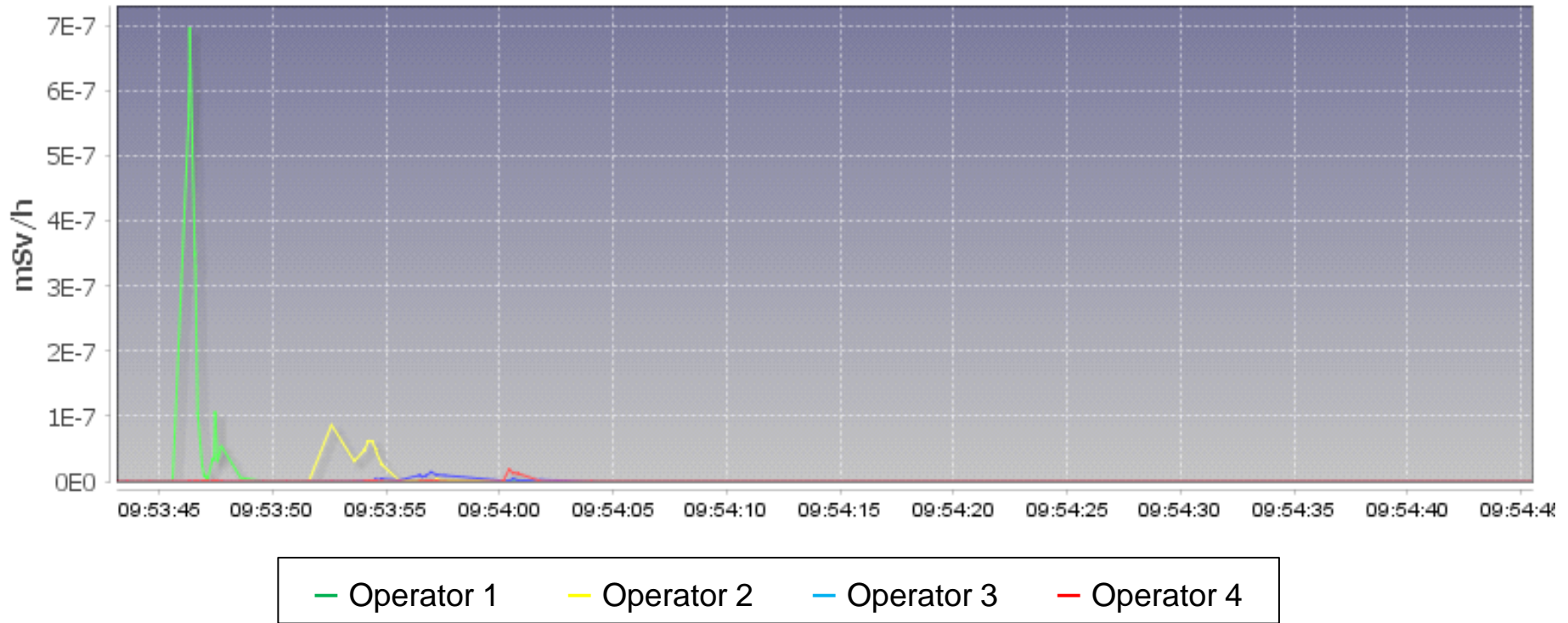

Pipe Thickness (mm)	Dose Rate (mSv/h)	Dose Rate (mSv/y)
25	7.00E-07	6.13E-03
15	2.40E-06	2.10E-02
10	5.50E-06	4.82E-02

# Simulation

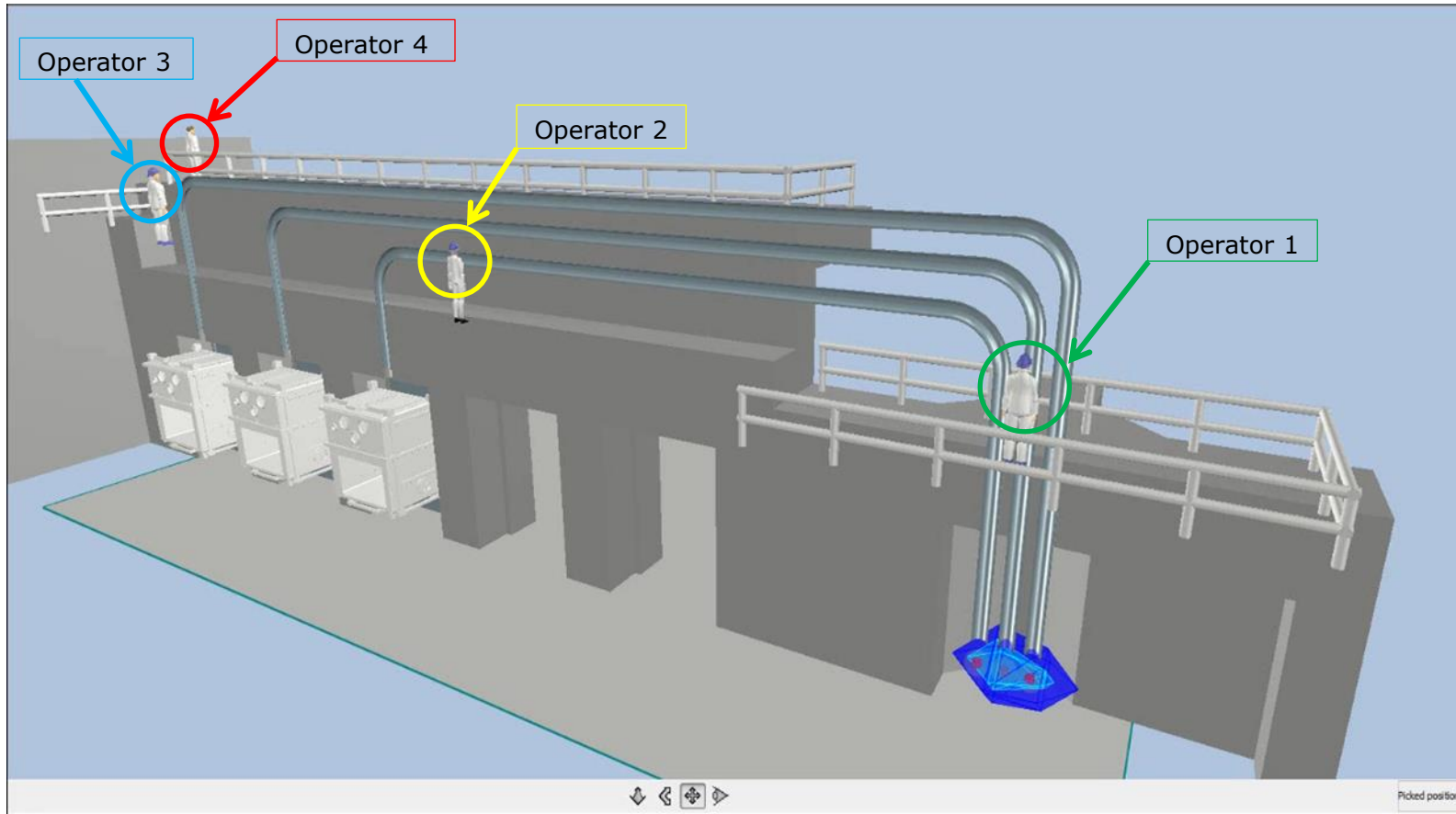

- Operator 1
- Operator 2
- Operator 3
- Operator 4

- Operators have been programmed to simulate maintenance work in PTS vicinity
- Present accident scenario whereby sources travel during maintenance

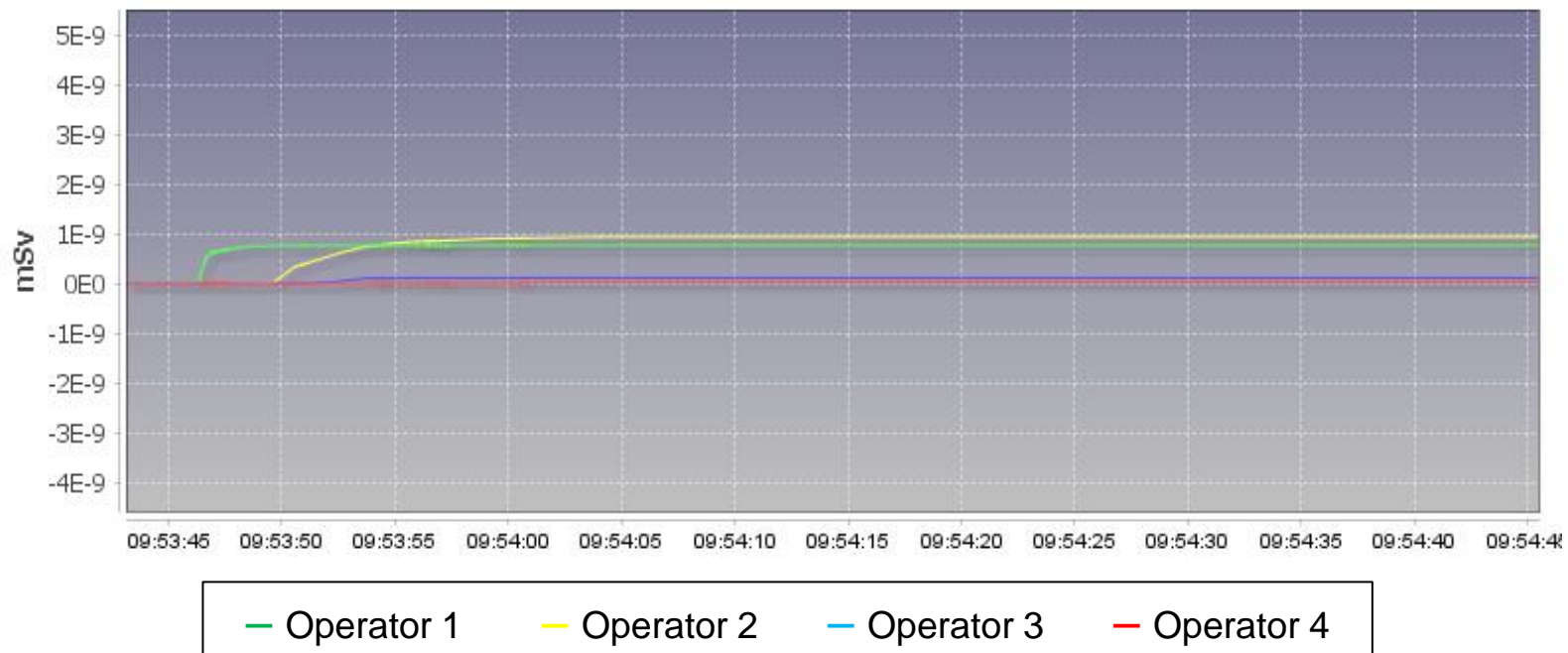

# Mal-Operation

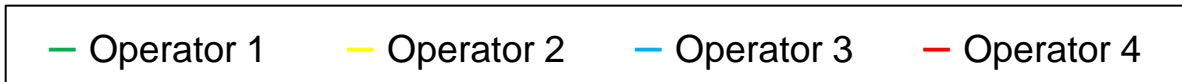
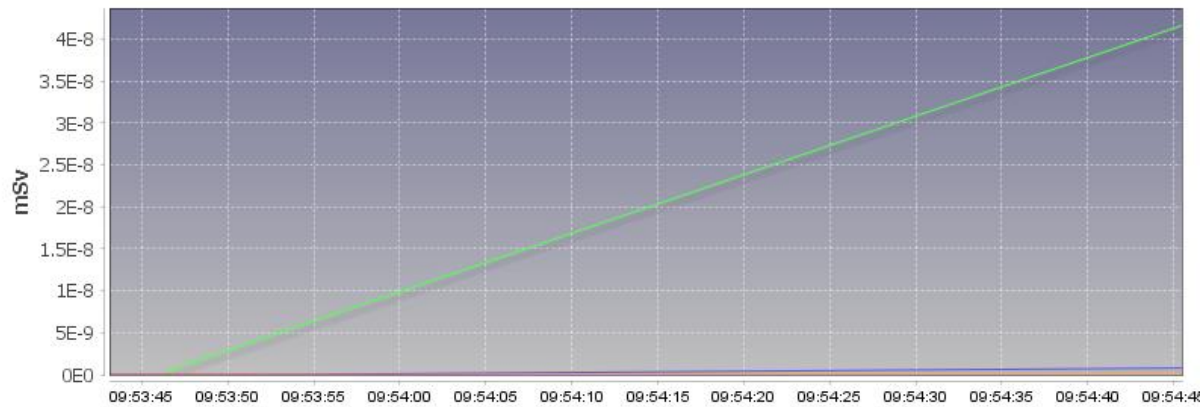
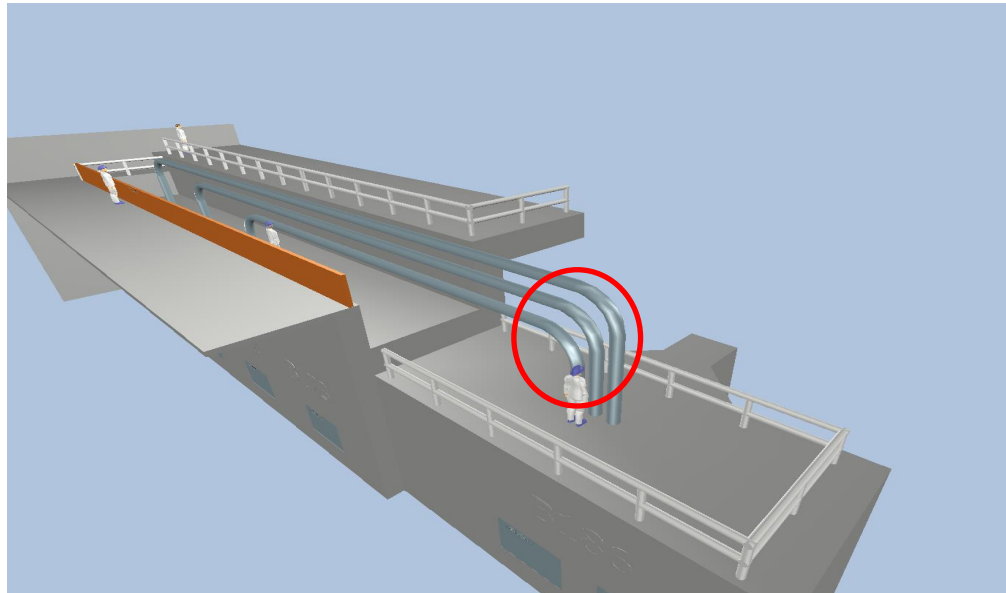

# Potential Future Design Process

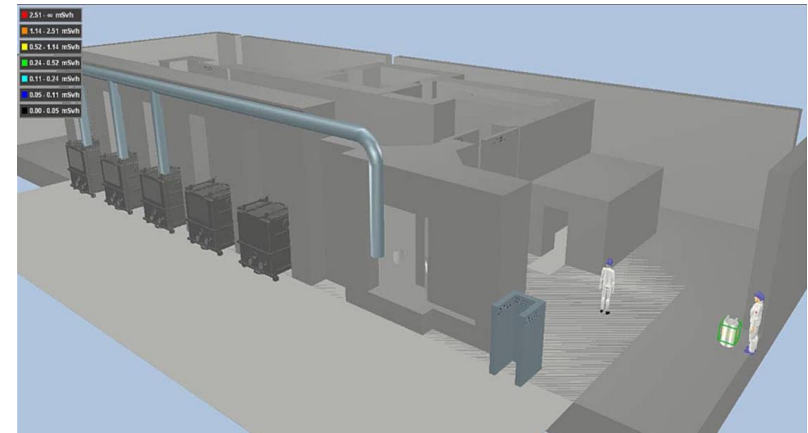
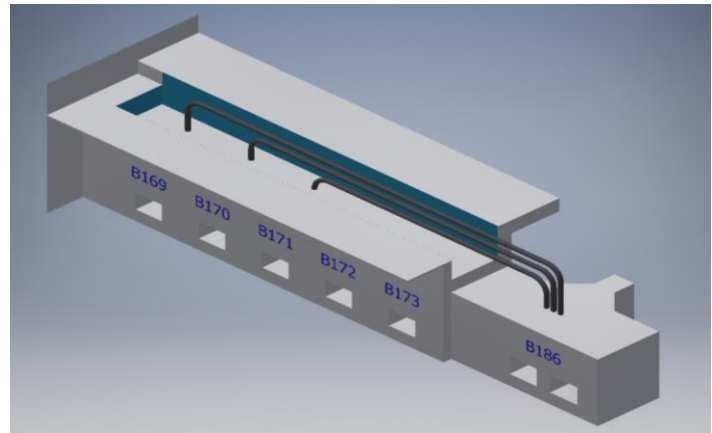
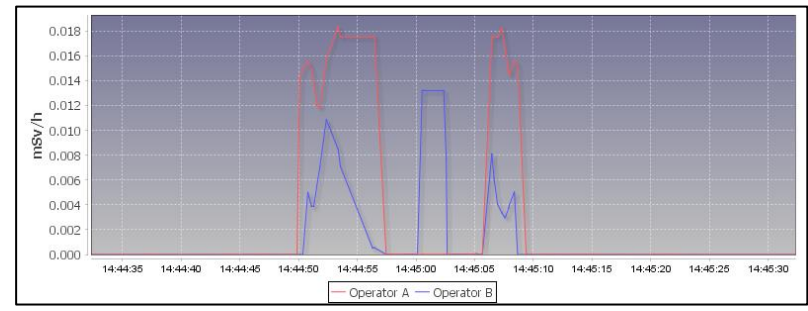
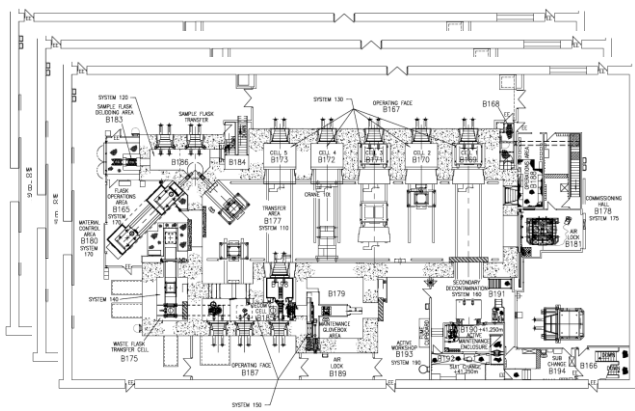

## Design

- Most engineering drawings are 2D isometric drawings which are not ideal for representing complex structures
- Operators and engineers rely on past experience and complex dose calculations during the design process which may be overly pessimistic
- Simulating the experiments and analyse ergonomic/ dose effects in a 3D virtual environment enables assessors from any discipline or background to interface with the virtual design and identify areas of concern with ease

## Safety Case

- Developing a safety case relies on the HAZOP process and multi-disciplinary teams sharing a common understanding of the designers vision for the process
- Most HAZOPs are undertaken with 2D technical drawings, complex calculations and operator experience input which can be subject to pessimistic assumptions and overinflated figures which need to be scaled down
- Inclusion of advanced simulation software has been 'proven' to speed up the process as the models make a system easier to understand, which speeds up safety case work and reduces scope for human error

## Decommissioning

- Ability to map out radiation and simulate dose uptake to an operator in dynamic conditions is particularly beneficial in decommissioning existing facilities
- Current practice involves the use of pessimistic assumptions and previous experience which often lead to inflated dose uptake values
- The software's ability to simulate dose in a 3D virtual twin of an active facility, place sources in the correct positions and simulate an operator route whilst recording dose uptake data is a powerful



- IR&D project focused on developing NNL's immersive and augmented modelling capabilities
- Allows NNL to accurately analyse the risks & constraints involved with working with radioactive material and develop effective safety procedures in a safe environment
- NNL can use the capabilities of the software to reduce costs, improve safety, streamline the design process and enhance public awareness
- Future applications of the programme requires building up NNL's capabilities via use on other projects (such as decommissioning)

- Chris Rhodes, Brendan Perry from NNL
- Michael Louka, Istvan Stoke from IFE



THANK YOU FOR LISTENING

ANY QUESTIONS?

**Qasim Kapasi**  
Qasim.a.kapasi@nnl.co.uk

